

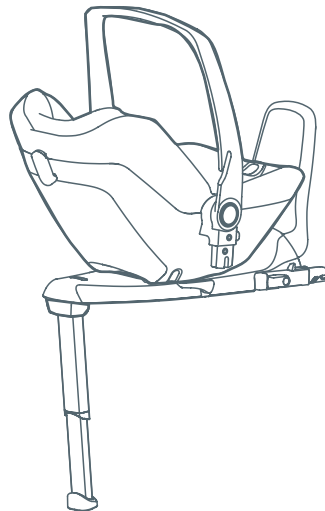

one



be cool







ESPAÑOL	13
ENGLISH	21
FRANÇAIS	29
PORTUGUÊS	37
ITALIANO	45





PARTLIST

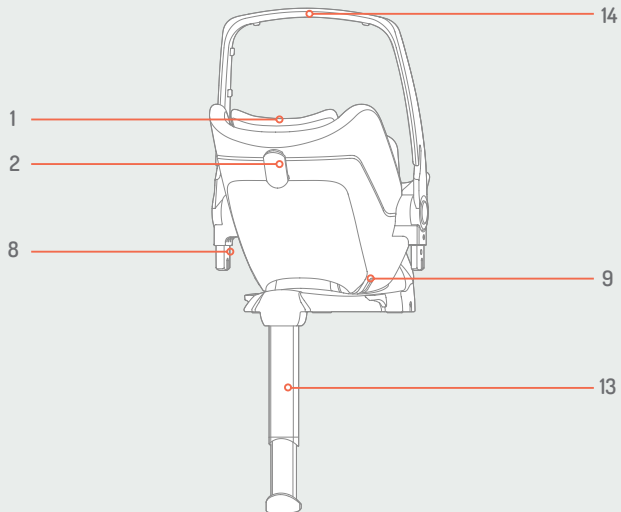

04



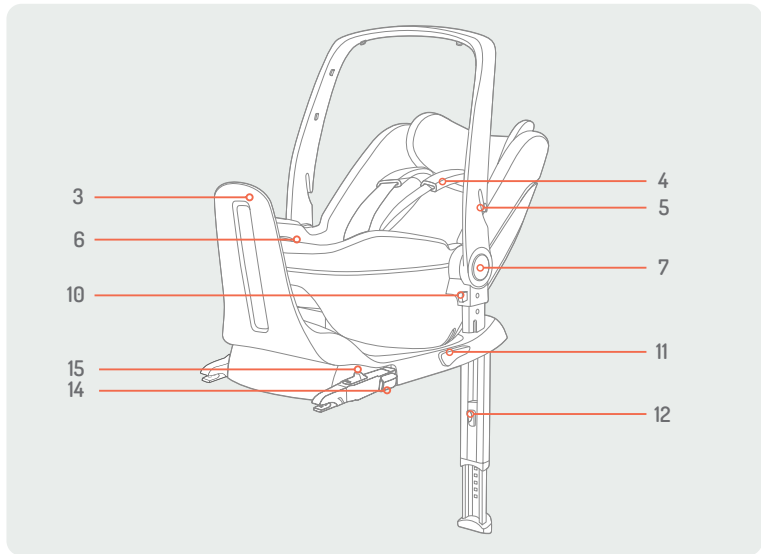

PARTLIST

05





INSTRUCTIONS

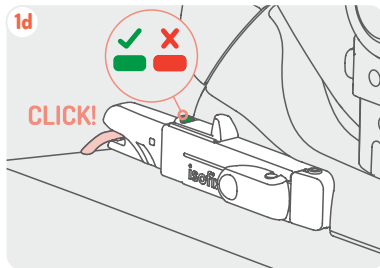
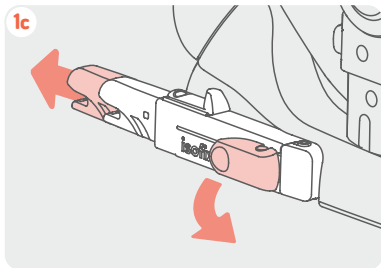
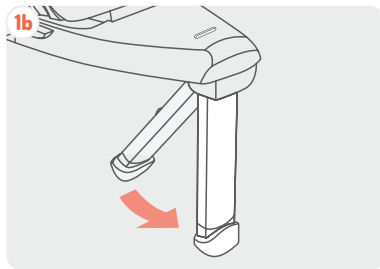
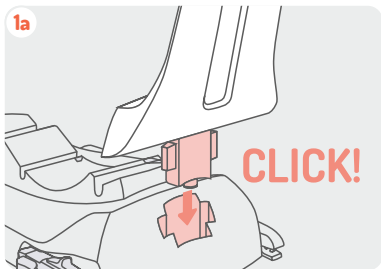

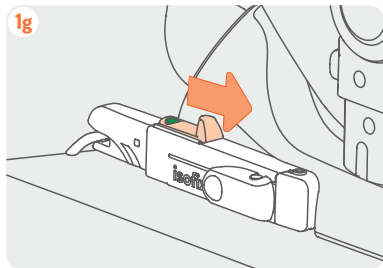
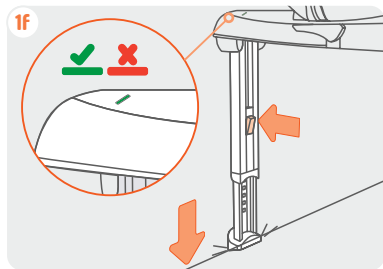
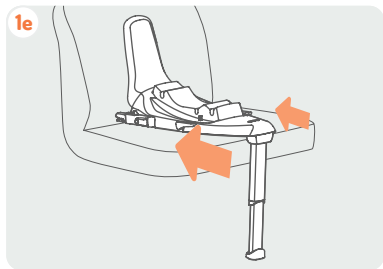



INSTRUCTIONS

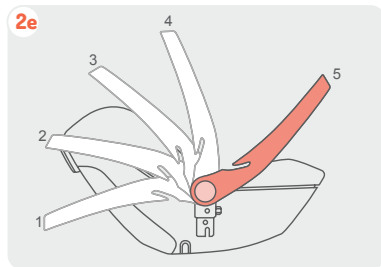
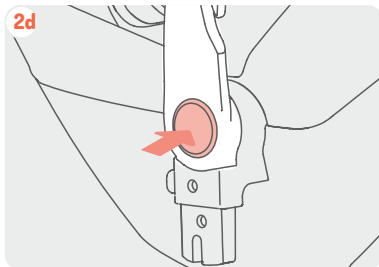
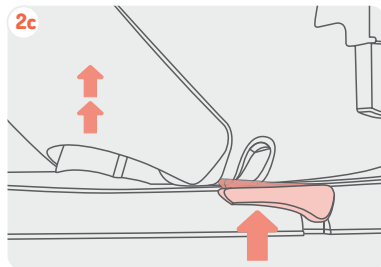
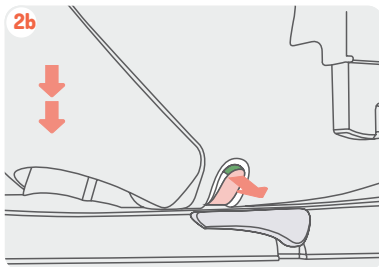

08



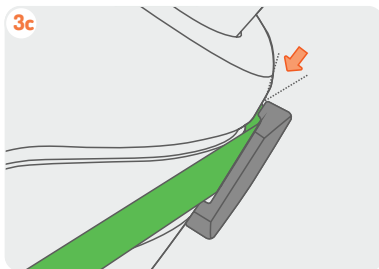
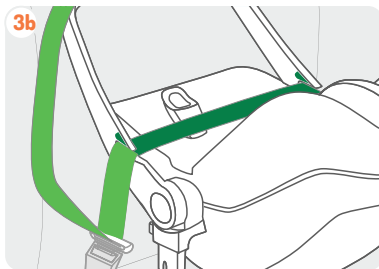
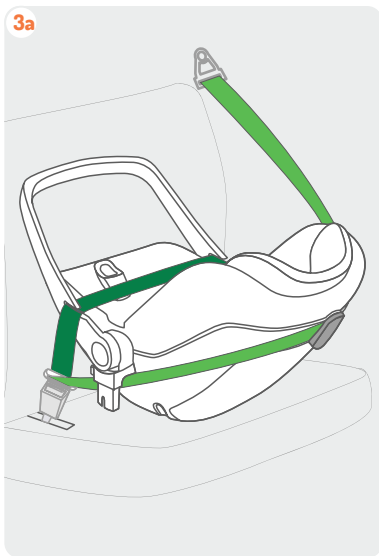



INSTRUCTIONS

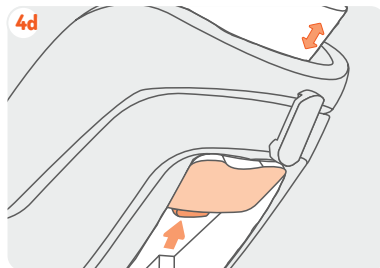
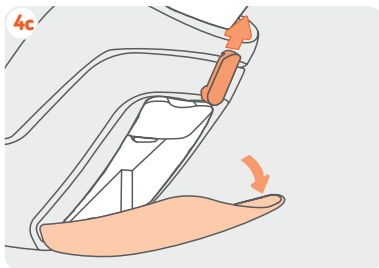
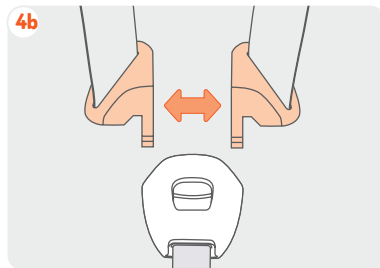
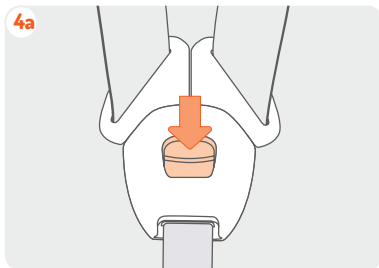

10



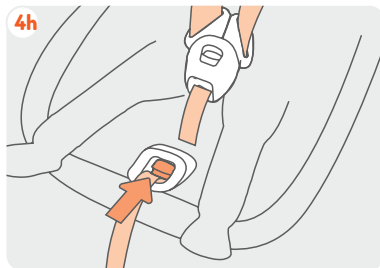
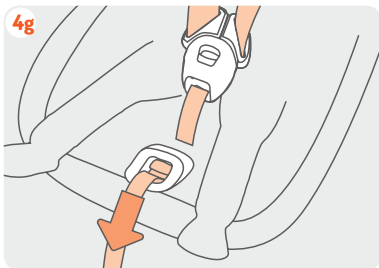
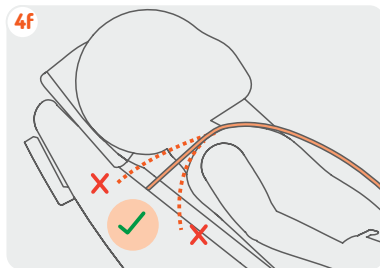
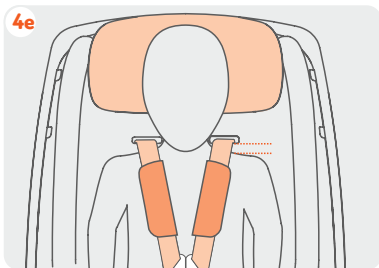

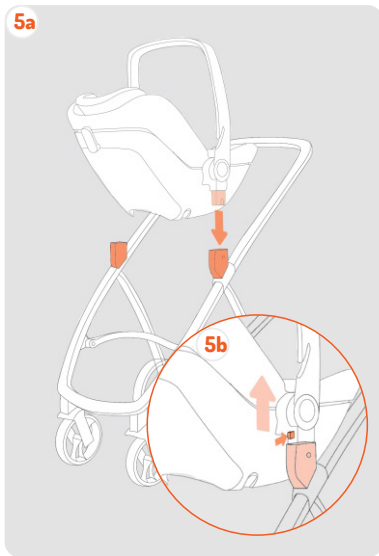



ES

ADVERTENCIAS	14
COMPONENTES	16
1. INSTALACIÓN DE LA BASE	17
2. INSTALACIÓN DE LA SILLA EN LA BASE	18
3. INSTALACIÓN DE LA SILLA CON CINTURÓN	18
4. ASEGURAR EL NIÑO EN LA SILLA	19
5. COLOCAR LA SILLA EN EL COHECITO	20
MANTENIMIENTO	21

13





ES

ADVERTENCIAS

Este sistema de retención infantil ha sido homologado según el Reglamento 129,01 para instalar niños entre 40 cm y 86 cm de altura.

No utilice la silla mirando hacia adelante en niños menores de 15 meses.

Por favor no deje al niño desatendido en el interior del vehículo.

Por favor lea cuidadosamente las instrucciones.

Una instalación incorrecta del sistema de retención infantil podría causar daños importantes al niño. En ese caso el fabricante no tendrá ningún tipo de responsabilidad.

Esta silla corresponde a la categoría isize definida en el Reglamento 129,01 de

Naciones Unidas y puede ser instalados en todos los vehículos isize homologados según el Reglamento 16.

Consulte el manual de instrucciones de su vehículo para saber si la instalación de sillas de retención infantil isize es posible.

No utilice la silla de seguridad sin la funda y sin los protectores de arnés.

Proteja el sistema de retención infantil del contacto directo de la luz solar, las partes plásticas y metálicas se pueden calentar y provocar quemaduras al niño.

14





Mantenga el sistema de retención infantil alejado de líquidos corrosivos, pinturas o disolventes que puedan dañar la integridad de la silla.

En caso de accidente debe sustituir el sistema de retención infantil, aunque visiblemente no haya daños. El producto podría tener daños internos no visibles que comprometan la seguridad del menor.

Haga paradas en su viaje para permitir al menor caminar y jugar fuera de la silla. No se recomienda viajar más de 2 horas seguidas sin hacer paradas. En caso de bebés este consejo es de gran importancia.

Asegurase que la pata de apoyo siempre esta en contacto con el suelo del vehículo, así como el arnés de fijación del niño esta correctamente ajustado y no tiene ninguna vuelta.

La funda textil es parte integral del sistema de retención infantil. No puede ser substituido por ningún otro sin la autorización expresa del fabricante.

No modifique el producto, quitando o añadiendo ningún accesorio o complemento.

Siga las instrucciones de montaje del producto detenidamente.

No deje equipaje en la bandeja posterior sin fijar ya que en caso de accidente su proyección podría provocar daños importantes a los ocupantes.

En caso de duda contacte con:

www.babybecool.es

ES

15



1. Reposacabezas
2. Guia de cinturón de seguridad
3. Sistema antirebote
4. Arnés de seguridad de 3 puntos
5. Guia de cinturón de seguridad
6. Botón de tensado del arnés
7. Botón de desbloqueo del asa
8. Sistema Profix
9. Indicador de instalación correcta de portabebes
10. Botón de desbloqueo del sistema Profix
11. Palanca de desbloqueo del portabebés
12. Botón de desbloqueo del sistema Profix
13. Pata de apoyo
14. Asa de transporte
15. Botón de desbloqueo Isofix
16. Botón de ajuste del Isofix



1. INSTALACIÓN DE LA BASE

Para instalar el sistema de retención infantil ONE siga estos pasos:

- 1a.** Instale el sistema antirotacional (3) hasta oír un “click”.
- 1b.** Despliegue la pata (13) hasta situarla en posición vertical como se muestra.
- 1c.** Mueva el botón (15) para deslizar el ISOFIX (14) hacia atrás desplegando totalmente el conector. Realice la misma operación para ambos conectores.
- 1d.** Guíe los conectores hacia los anclajes ISOFIX de su vehículo hasta que enganchen haciendo un “click” y el indicador pase de rojo a verde en ambos lados de la base.
- 1e.** Desplace la silla hacia atrás presionándola contra el respaldo del asiento del vehículo. Después tire de la silla hacia usted para asegurarse que la silla esta correctamente fijada.

1f. Pulse el botón (12) para ajustar la altura de la pata de apoyo (13) hasta asegurar que está en contacto con el suelo. No debe quedar encima de ningún compartimento. En este punto asegúrese que la posición de la pata de apoyo con respecto a la base de la silla marca un ángulo de 90°.

Los indicadores visuales del ISOFIX marcan si el conector esta cerrado o abierto. Podría suceder que éste esté cerrado sin estar anclado en el anclaje ISOFIX. Por favor verifique tirando de la silla una vez instalada que los conectores están cerrados correctamente en el anclaje del vehículo.

Para desinstalar la silla siga los pasos a la inversa:

1g. Mover el botón (10) para abrir el conector y poder liberar los anclajes.

ES



2. INSTALACIÓN DE LA SILLA EN LA BASE

Para colocar la silla en la base siga los siguientes pasos:

2a. Dejar caer suavemente el portabebes sobre la base.

2b. Comprobar que se ha anclado de los dos lados, su portabebé esta correctamente fijado cuando oiga un click y vea que la pieza en la base del portabebé (9) se muestra el color verde.

2c. Para retirar el portabebé de la base, levante la palanca de la base (11) y tire hacia arriba.

2d. Girar el asa en la posición número 4 o 2, como se muestra en la figura 2e.

3. INSTALACIÓN DE LA SILLA CON CINTURÓN

Para colocar el portabebé sin la base se utilizará el cinturón del coche de la siguiente manera:

3a. Coloque el portabebes en el asiento del vehículo, poniendo el asa de transporte en la posición 5 según se muestra en la figura 2e. Fije el cinturón de seguridad pasandolo por encima del asa de transporte.

3b. Introduzca la parte abdominal del cinturón del automovil por las ranuras en la asa (5).

3c. La parte diagonal del cinturón de seguridad del vehículo debe pasarse por la parte posterior del portabebes, pasando la cinta por la guía de cinturón (2). Tense el cinturón del automovil.

Saque las holguras de la cinta del cinturón de seguridad del vehículo tirando de la parte diagonal de este hasta que la silla quede fuertemente anclada.



4. ASEGURAR EL NIÑO EN LA SILLA

Uso de cojin reductor.

Utilice el cojin reductor desde el nacimiento hasta los 61 cm aproximadamente. Es recomendable el uso del cojin reductor más alla de los 61 cm, siempre que sea compatible con el tamaño del bebe.

Colocar el niño en la silla.

4a. Abra la hebilla pulsando el boton rojo, apartando los conectores para facilitar la instalación del bebe.

4b. Acomode al bebe en la silla, y pongale el arnes de seguridad fijando la hebilla.

4c. Para ajustar el apoya cabezas, abra la tapa en la parte posterior del portabebé. Desplace la guia del cinturón (2) hacia arriba para dejar caer la tapa.

4d. Apretar la palanca para regular la altura del reposacabezas.

4e. Debe quedar en la posición correcta, esto significa que la salida del arnés en la zona de los hombros debe hacerlo aproximadamente 1 cm por encima de los hombros **4f.** Volver a cerrar a tapa.

4g. Una vez el niño esta colocado correctamente, tense el arnés tirando de la cinta asegurando que queda bien ajustado.

Se entiende por tensión correcta dejar entre la cinta del arnés y el bebe a la altura del pecho no más de un 1 cm. de holgura. (colocar un dedo entre el bebe y el arnés)

Sacar al niño del asiento.

4h. Destensar los cinturones del arnés presionado el botón de tensado. Posteriormente abrir la hebilla y sacar al niño **4a.**

ATENCIÓN! Los cinturones no deben quedar retorcidos. El cierre del arnés debe quedar correctamente cerrado y los cinturones deben quedar bien ajustados al niño.

ES

5. COLOCAR LA SILLA EN EL COCHECITO

5a. Con el asa en posición 4 (figura 2e), encajar el portabebé con el anclaje del cochecito hasta oír un click.

5b. Para retirar el portabebé del cochecito apretar el botón del profix (10) tirando hacia arriba el portabebes.

MANTENIMIENTO

Retirar / Colocar la funda

La funda de la silla ONE es muy sencilla de quitar. En la parte frontal hay 2 puntos de fijación de la funda.

Por favor libere estos puntos y estire suavemente la parte frontal de la funda.

En los laterales de la silla hay unas piezas plásticas que sirven para la fijación de la funda. Simplemente estire con suavidad para poder sacar la funda.

Para volver a colocar la funda haga el proceso inverso. Para los laterales coloque la piezas en la ranura.

Limpieza

La funda puede ser lavada a maquina usando detergente suave y a una temperatura máxima de 30°. Por favor observe las instrucciones de lavado en la etiqueta de la funda.

No utilice secadora ya que el acolchado podría separarse del textil.

No exponga el tapizado al sol durante largos periodos, mientras la silla no esté en uso cúbrala o guárdela en el compartimiento porta equipajes.

Las partes plásticas pueden limpiarse con un paño húmedo y detergente neutro.

Recomendaciones

Guarde este libro de instrucciones para futuras consultas. Llévelo siempre en el compartimiento debajo de la base. Asegúrese que dentro del automóvil, tanto el equipaje como cualquier otro objeto susceptible de causar años en caso de accidente estén debidamente fijados o resguardados.



SAFETY WARNINGS	22
PARTS	24
1. INSTALLING THE BASE	25
2. INSTALLING THE SEAT ON THE BASE	26
3. INSTALLING THE SEAT WITH THE SEAT BELT	26
4. FASTENING THE CHILD IN THE SEAT	27
5. FITTING THE SEAT ONTO THE PRAM	28
MAINTENANCE	28





EN

SAFETY WARNINGS

This child restraint system has been certified under Regulation 129.01 to be used by children of between 40 cm and 86 cm in height.

Do not use the seat in the forward facing position with children under 15 months old.

Please do not leave the child unattended in the vehicle.

Please read these instructions carefully.

Incorrect installation of the child restraint system can cause the child serious injuries. If this occurs, the manufacturer will not be liable in any way.

This safety seat is included in the i-Size category defined in Regulation 129.01 of the United Nations and it can be installed in all i-Size vehicles approved under Regulation

16.

Check the instruction manual for your vehicle to see if i-Size restraint systems can be installed.

Do not use the safety seat without the cover and without the harness pads.

Keep the child restraint system out of direct sunlight, the plastic and metal parts can get hot and burn the child.

Keep the child restraint system away from corrosive fluids, paints or solvents that could damage the safety seat.

The child restraint system should be replaced after an accident, even if there are no

22





visible signs of damage. The product could have internal damage that is not visible but which may compromise the child's safety.

Remember to take breaks on your journey to allow the child to walk and play out of the safety seat. It is not advisable to travel for more than 2 hours without taking a break. This advice is especially important for babies.

Make sure that the support leg is always in contact with the floor of the vehicle, and that the harness securing the child is fitted correctly and is not twisted.

The fabric cover is an important part of the child restraint system. It must not be replaced by any other cover without explicit authorisation from the manufacturer.

Do not make any changes to the product, or add or remove any accessories or parts.

Follow the product assembly instructions carefully.

Do not leave any luggage on the parcel shelf of the vehicle without securing it because in the event of an accident it could cause significant injury to the vehicle occupants.

If you have any questions please contact:

www.babybecool.es

EN

23



1. Headrest
2. Seat belt guide
3. Anti-bounce system
4. 3-point safety harness
5. Seat belt guide
6. Harness tension button
7. Handle unlock button
8. Profix system
9. Baby carrier correct installation indicator
10. Profix system unlock button
11. Baby carrier unlock lever
12. Profix system unlock button
13. Support leg
14. Carry handle
15. Isofix unlock button
16. Isofix adjustment button



1. INSTALLING THE BASE

To install the ONE child restraint system, follow the steps below:

- 1a.** Attach the anti-swivel system (3) it will click into place
- 1b.** Unfold the leg (13) until it is in the vertical position as shown.
- 1c.** Move the button (15) to slide the ISOFIX (14) backwards until the connector is completely unfolded. Do the same operation for both connectors.
- 1d.** Guide the connectors towards the ISOFIX anchors in your vehicle until they click into place and the indicator changes from red to green on both sides of the base.
- 1e.** Push the seat backwards pressing it against the backrest of the vehicle seat. Then try to pull the seat towards you to make sure that it is correctly secured in place.

- 1f.** Press the button (12) to adjust the height of the support leg (13) to ensure that it is touching the floor. It should not be placed on top of any type of compartment. At this point make sure that the position of the support leg is at an angle of 90° from the seat base.

The visual ISOFIX indicators will show whether the connector is closed or open. It may be that the connector is closed without being secured in the ISOFIX anchor. Please check this by pulling the seat once the connectors are correctly locked into the vehicle anchors.

To remove the seat, follow the same steps in reverse order:

- 1g.** Move the button (10) to open the connector and release the anchors.

EN





EN

2. INSTALLING THE SEAT ON THE BASE

To attach the safety seat to the base, follow the steps below:

- 2a.** Let the baby carrier drop gently into place on the base.
- 2b.** Check that both sides are locked into place; the baby carrier is correctly secured when you hear it click into place and the part on the base of the baby carrier (9) displays the green signal.
- 2c.** To detach the baby carrier from the base, raise the lever on the base (11) and pull upwards.
- 2d.** Turn the handle to position number 4 or 2, as shown in diagram 2e.

3. INSTALLING THE SEAT WITH THE SEAT BELT

To install the baby carrier without the base the car seat belt is used as indicated below:

- 3a.** Position the baby carrier on the vehicle seat, setting the carry handle to position number 5 as shown in diagram 2e. Fasten the seat belt passing it over the carry handle.
- 3b.** Insert the lap belt section of the seat belt through the slots in the handle (5).
- 3c.** The diagonal section of the vehicle seat belt should go around the back of the baby carrier, passing the belt through the seat belt guide (2). Tighten the vehicle seat belt appropriately.

Get rid of any loose sections of the seat belt by pulling the diagonal part until the seat is firmly anchored in place.

26



4. FASTENING THE CHILD IN THE SEAT

Using the cushion insert.

Use the cushion insert from birth until the child measures 61 cm approximately. It is advisable to use the cushion insert after the child is bigger than 61 cm, provided that it is compatible with the baby's size.

Putting the child in the safety seat.

- 4a.** Open the buckle by pressing the red button, separating the connectors to make it easier to put the child in..
- 4b.** Settle the child comfortably in the seat, and put the safety harness on fastening the buckle.
- 4c.** To adjust the headrest, open the compartment on the back of the baby carrier. Move the seat belt guide (2) upwards to let the compartment drop open.
- 4d.** Press the lever to adjust the height of the headrest.

4e. It should be placed in the right position, this means that the harness should come out approximately 1 cm above the child's shoulders **4f.** Close the compartment again.

4g. Once the child is positioned correctly, tighten the harness by pulling the strap making sure that it fits snugly.

The correct tension means that between the harness strap and the baby's chest there should be a gap of no more than 1 cm. (just enough to slide one finger between the baby and the harness).

Getting the child out of the safety seat.

4h. Loosen the harness straps by pressing the tension button. Then unfasten the buckle and lift the child out **4a.**

WARNING! The straps must not be twisted. The harness must be correctly fastened and the straps should fit the child snugly.



EN

5. FITTING THE SEAT ONTO THE PRAM

5a. With the handle set to position 4 (diagram 2e), slot the baby carrier onto the pram anchors until you hear it click into place.

5b. To detach the baby carrier from the pram, press the profix button (10) and pull the baby carrier upwards.

MAINTENANCE

Removing / Fitting the cover

The cover of the ONE seat is very easy to take off. On the front part there are 2 fastening points for the cover. Unfasten these two points and gently pull the front part of the cover.

On the sides of the seat there are some plastic parts designed to hold the cover in place. Simply pull the cover over them gently to take it off.

To fit the cover back on again, follow the same steps in reverse. Place the parts in the slot for the sides.

Cleaning

The cover can be machine washed using mild detergent and at a maximum temperature of 30o. Please follow the washing instructions on the care label of the cover.

Do not tumble dry as this could cause the padding to come away from the fabric.

Do not expose the upholstery to sunlight for prolonged periods of time, when the seat is not in use cover it up or store it in the car boot.

The plastic parts can be cleaned with a damp cloth and neutral detergent.

Recommendations

Keep this instruction book for future reference. Always keep it in the compartment under the base. In the vehicle, make sure that any luggage or other objects that could cause injury in the event of an accident are securely fastened or stored.

28





MISES EN GARDE	30
COMPOSANTS	32
1. INSTALLATION DE LA BASE	33
2. INSTALLATION DU SIÈGE COQUE SUR LA BASE	34
3. INSTALLATION DU SIÈGE COQUE AVEC LA CEINTURE	34
4. ATTACHER L'ENFANT DANS LE SIÈGE COQUE	35
5. POSER LE SIÈGE COQUE SUR LA POUSETTE	36
ENTRETIEN	36

MISES EN GARDE

Ce système de retenue pour enfant est conforme au règlement 129,01 et peut être utilisé pour installer des enfants dont la taille est comprise entre 40 et 86 cm.

Le siège coque ne doit pas être installé face à la route si les enfants sont âgés de moins de 15 mois.

Ne laissez pas votre enfant sans surveillance à l'intérieur du véhicule.

Veillez lire attentivement les instructions.

Une mauvaise installation du système de retenue pour enfant peut entraîner de graves blessures pour votre enfant. Dans ce cas, la responsabilité du fabricant ne pourra être engagée.

Ce siège coque correspond à la catégorie

i-Size définie dans le règlement 129,01 des Nations Unies et il peut être installé dans tous les véhicules i-Size homologués conformément au règlement 16.

Veillez consulter le manuel de votre véhicule pour vérifier si l'installation du système de retenue pour enfant i-Size est possible.

Le système de retenue ne doit pas être utilisé sans housse ni sans les protecteurs du harnais de sécurité.

Veillez à protéger le système de retenue pour enfants contre les rayons directs du soleil : les parties en plastique et métalliques risquent de chauffer et de brûler l'enfant.



Veillez à ne pas tenir le système de retenue pour enfants près de liquides corrosifs, de peintures ou de dissolvants qui risquent d'endommager le siège coque.

En cas d'accident, vous devrez remplacer le système de retenue pour enfant même s'il ne présente aucun dommage apparent. Le système peut présenter des dommages internes qui ne sont pas visibles à l'œil nu et ne plus garantir la sécurité de l'enfant.

Pensez à faire des arrêts lors de vos voyages afin que votre enfant puisse se dégonfler les jambes et s'amuser hors de son siège auto. Il est recommandé de s'arrêter toutes les 2 heures. Pour les bébés, ce conseil est essentiel.

Vérifiez si la jambe de force reste en contact avec le plancher du véhicule et si le harnais de sécurité de l'enfant est bien

ajusté et n'est pas tordu.

La housse en tissu fait partie du système de retenue pour enfant. Elle ne doit pas être remplacée par une housse autre que celle homologuée par le fabricant.

Vous ne devez pas modifier cet article en retirant ou en ajoutant un accessoire ou un complément.

Veillez suivre rigoureusement les indications de montage du produit.

Veillez à bien attacher les affaires que vous laissez sur la plage arrière car en cas d'accident, leur projection risquerait de provoquer de graves blessures pour les passagers.

En cas de doute, veuillez consulter notre site Internet : www.babybecool.es

FR



1. Appuie-tête
2. Guide de ceinture de sécurité
3. Système anti-rebond
4. Harnais de sécurité à 3 points
5. Guide de ceinture de sécurité
6. Bouton de réglage du harnais
7. Bouton de déblocage de l'anse
8. Système Profix
9. Témoin de bonne installation du siège coque
10. Bouton de déblocage du système Profix
11. Levier de déblocage du siège coque
12. Bouton de déblocage du système Profix
13. Jambe de force
14. Anse de transport
15. Bouton de déblocage de l'Isofix
16. Bouton de réglage de l'Isofix



1. INSTALLATION DE LA BASE

Veuillez suivre les étapes suivantes pour installer le système de retenue pour enfant ONE :

- 1a.** Installez le système anti-rotation (3) ; vous devez entendre un clic.
- 1b.** Dépliez la jambe de force (13) pour la mettre à la verticale comme indiqué.
- 1c.** Déplacez le bouton (15) pour faire glisser l'ISOFIX (14) vers l'arrière et déplier complètement le connecteur. Réalisez la même opération pour les deux connecteurs.
- 1d.** Guidez les connecteurs vers les ancrages ISOFIX de votre véhicule et emboîtez-les jusqu'à entendre un clic. Le témoin passera du rouge au vert des deux côtés de la base.
- 1e.** Poussez le siège coque vers l'arrière contre le dossier du véhicule. Puis tirez le siège coque vers vous afin de vérifier s'il est bien fixé.

1f. Appuyez sur le bouton (12) pour régler la hauteur de la jambe de force (13) qui doit reposer sur le plancher du véhicule. Elle ne doit pas se trouver sur un compartiment. Vous devez alors vous assurer que la position de la jambe de force fait un angle de 90° par rapport à la base du siège coque.

Les témoins de l'ISOFIX indiquent si le connecteur est ouvert ou fermé. Il se peut que ce dernier soit fermé sans être emboîté dans l'ancrage ISOFIX. Veuillez vérifier en tirant sur le siège coque après avoir enclenché correctement les connecteurs dans l'ancrage du véhicule..

Pour retirer le siège coque, veuillez suivre les étapes dans le sens inverse:

1g. Déplacez le bouton (10) pour ouvrir le connecteur et libérer les ancrages.

FR

2. INSTALLATION DU SIÈGE COQUE SUR LA BASE

Pour poser le siège coque sur la base, veuillez suivre les étapes suivantes:

- 2a.** Laissez tomber le siège coque doucement sur la base..
- 2b.** Vérifiez s'il est emboîté des deux côtés. Votre siège coque sera correctement fixé lorsque vous entendrez un clic et que vous verrez que l'élément de la base du porte-bébé (9) est vert.
- 2c.** Pour retirer le siège coque de la base, levez le levier de la base (11) et tirez vers le haut.
- 2d.** Mettez l'anse dans la position numéro 4 ou 2 comme indiqué sur la figure 2e.

3. INSTALLATION DU SIÈGE COQUE AVEC LA CEINTURE DE SÉCURITÉ

Pour poser le siège coque sans la base, il faudra utiliser la ceinture de sécurité du véhicule de la sorte :

- 3a.** Posez le siège coque sur le siège du véhicule en mettant l'anse de transport sur la position 5 tel qu'indiqué sur la figure **2e**. Fixez la ceinture de sécurité en la passant sur l'anse de transport.
- 3b.** Introduisez la sangle abdominale de la ceinture de sécurité du véhicule dans les rainures de l'anse (5).
- 3c.** La partie diagonale de la ceinture de sécurité du véhicule doit passer sur la partie postérieure du siège coque, en passant la sangle dans le guide de la ceinture (2). Tendez la ceinture de sécurité du véhicule.

Tendez les parties lâches de la ceinture de sécurité du véhicule en tirant sur la partie diagonale de celle-ci jusqu'à ce que le siège coque soit bien fixé



4. ATTACHER L'ENFANT DANS LE SIÈGE COQUE

Utilisation du coussin réducteur.

Utilisez le coussin réducteur dès la naissance jusqu'à 61 cm environ. Le coussin réducteur peut être utilisé au-delà des 61 cm à condition que la taille de l'enfant le permette.

Installer l'enfant dans le siège coque.

4a. Ouvrez la boucle en appuyant sur le bouton rouge et écartez les connecteurs pour pouvoir installer votre bébé.

4b. Installez votre bébé dans le siège coque et attachez le harnais de sécurité au moyen de la boucle.

4c. Ouvrez le couvercle de la partie postérieure du siège coque afin de régler l'appuie-tête. Tournez le guide de la ceinture de sécurité (2) vers le haut et laissez tomber le couvercle.

4d. Utilisez le levier afin de régler la hauteur de l'appuie-tête.

4e. Une bonne position de l'appuie-tête signifie que le départ du harnais se trouve à environ 1 cm au-dessus des épaules **4f.** Refermez le couvercle.

4g. Une fois l'enfant bien installé, tendez le harnais en tirant sur la sangle et assurez-vous qu'elle est bien ajustée.

Une bonne tension ne doit pas laisser un jeu de plus d'1 cm entre la sangle du harnais et le bébé au niveau de la poitrine. (Passez un doigt entre le bébé et le harnais).

Sortir l'enfant du siège coque.

4h. Détendez les sangles du harnais en appuyant sur le bouton de réglage. Ouvrez la boucle et sortez l'enfant **4a.**

ATTENTION ! Les ceintures de sécurité ne doivent pas être tordues. La boucle du harnais doit être bien fermée et les sangles doivent être bien ajustées à l'enfant.

FR



5. INSTALLER LE SIÈGE COQUE SUR LA POUSSETTE

5a. Avec l'anse sur la position 4 (figure 2e), emboîtez le siège coque dans la fixation de la poussette jusqu'à ce que vous entendiez un clic

5b. Pour retirer le siège coque de la poussette, appuyez sur le bouton du profix (10) en tirant le siège coque vers le haut.

MAINTENANCE

Retirer / Poser la housse

La housse du siège ONE est très simple à retirer. La partie avant présente 2 points d'attache pour la housse. Détachez ces points et tirez doucement sur la partie avant de la housse.

Des pièces en plastique se trouvent sur les côtés du siège pour attacher la housse. Tirez doucement pour retirer la housse.

Pour remettre la housse, veuillez procéder dans le sens inverse. Introduisez les pièces dans la rainure sur les côtés.

Nettoyage

La housse peut être lavée en machine, avec une lessive neutre, à une température maximum de 30°. Veuillez suivre les indications de lavage de l'étiquette de la housse.

Ne passez pas la housse au sèche-linge car le rembourrage risque de se séparer du tissu.

Veillez à ne pas exposer le tissu au soleil pendant des périodes prolongées. Couvrez votre siège lorsque vous ne l'utilisez pas ou rangez-le dans le coffre.

Les parties en plastique peuvent être nettoyées avec un chiffon humide et un produit nettoyant neutre.

Recommandations

Veillez conserver cette notice d'instructions pour toute consultation ultérieure. Conservez-la dans le compartiment qui se trouve sous la base du siège. Veillez à ce que les affaires ou tout autre objet susceptibles de provoquer des blessures en cas d'accident soient bien attachés ou rangés à l'intérieur du véhicule.



ADVERTÊNCIAS	38
COMPONENTES	40
1. INSTALAÇÃO DA BASE	41
2. INSTALAÇÃO DA CADEIRA NA BASE	42
3. INSTALAÇÃO DA CADEIRA COM CINTO	42
4. SEGURAR A CRIANÇA NA CADEIRA	43
5. COLOCAR A CADEIRA NO CARRINHO	44
MANUTENÇÃO	44





PT

ADVERTÊNCIAS

Este sistema de retenção infantil foi homologado segundo o Regulamento 129,01 para instalar crianças entre 40 cm e 86 cm de altura.

Não utilize a cadeira virada para a frente com crianças menores de 15 meses.

Por favor, não deixe a criança sozinha no interior do veículo.

Por favor, leia cuidadosamente as instruções.

Uma instalação incorreta do sistema de retenção infantil pode causar lesões importantes à criança. Nesse caso, o fabricante não assumirá qualquer tipo de responsabilidade.

Esta cadeira corresponde à categoria isize

definida no Regulamento 129,01 das Nações Unidas e pode ser instalada em todos os veículos isize homologados segundo o Regulamento 16.

Consulte o manual de instruções do seu veículo para saber se é possível a instalação de cadeiras de retenção infantil isize.

Não utilize a cadeira de segurança sem a fronha e sem os protetores de arnês.

Proteja o sistema de retenção infantil do contacto direto da luz solar, as partes plásticas e metálicas podem aquecer e provocar queimaduras na criança.

Mantenha o sistema de retenção infantil afastado de líquidos corrosivos, tintas

38





ou dissolventes que possam danificar a integridade da cadeira.

Em caso de acidente deve substituir o sistema de retenção infantil, ainda que aparentemente não se verifiquem danos. O produto pode ter danos internos não visíveis que comprometam a segurança do menor.

Efetue paragens durante a sua viagem para permitir ao menor caminhar e brincar fora da cadeira. Não é recomendável viajar mais de 2 horas seguidas sem fazer paragens. No caso de bebês este conselho é muito importante.

Assegure-se de que o pé de apoio está sempre em contacto com o solo do veículo, assim como se o arnês de fixação da criança está corretamente ajustado e não tem nenhuma volta.

A fronha têxtil é parte integral do sistema de retenção infantil. Não pode ser substituída por nenhuma outra sem a autorização expressa do fabricante.

Não modifique o produto, retirando ou acrescentando qualquer acessório ou complemento.

Siga pormenorizadamente as instruções de montagem do produto.

Não deixe bagagem na bandeja posterior sem fixar, já que em caso de acidente a sua projeção poderia provocar lesões importantes aos ocupantes.

Em caso de dúvida contacte com:

www.babybecool.es

PT



1. Apoio para a cabeça
2. Guia de cinto de segurança
3. Sistema anti-ricochete
4. Arnês de segurança de 3 pontos
5. Guia de cinto de segurança
6. Botão tensor do arnês
7. Botão de desbloqueio da asa
8. Sistema Profix
9. Indicador de instalação correta do porta-bebés
10. Botão de desbloqueio do sistema Profix
11. Alavanca de desbloqueio do porta-bebés
12. Botão de desbloqueio do sistema Profix
13. Pé de apoio
14. Asa de transporte
15. Botão de desbloqueio Isofix
16. Botão de ajuste do Isofix



1. INSTALAÇÃO DA BASE

Para instalar o sistema de retenção infantil ONE siga estes passos:

- 1a.** Instale o sistema anti-rotacional (3) até escutar um “clique”.
- 1b.** Desdobre o pé (13) até situá-lo em posição vertical, tal como é mostrado.
- 1c.** Mova o botão (15) para deslizar o ISOFIX (14) para trás desdobrando totalmente o conector. Realize a mesma operação para ambos os conectores.
- 1d.** Guie os conectores para as fixações ISOFIX do seu veículo até que engatem fazendo um “clique” e o indicador passe de vermelho a verde em ambos os lados da base.
- 1e.** Desloque a cadeira para trás pressionando-a contra o encosto do assento do veículo. Depois puxe a cadeira para si de modo a assegurar-se de que a cadeira está corretamente fixada.

1f. Pressione o botão (12) para ajustar a altura do pé de apoio (13) até assegurar-se de que está em contacto com o solo. Não deve ficar em cima de nenhum compartimento. Neste ponto assegure-se que a posição do pé de apoio relativamente à base da cadeira marca um ângulo de 90°.

Os indicadores visuais do ISOFIX marcam se o conector está fechado ou aberto. Pode suceder que este esteja fechado sem estar fixado na fixação ISOFIX. Por favor, verifique puxando a cadeira, uma vez instalada, se os conectores estão corretamente fechados na fixação do veículo.

Para desinstalar a cadeira siga os passos na inversa:

1g. Mover o botão (10) para abrir o conector e poder soltar as fixações.



2. INSTALAÇÃO DA CADEIRA NA BASE

Para colocar a cadeira na base siga os seguintes passos:

2a. Deixar cair suavemente o porta-bebês sobre a base.

2b. Comprovar se ficou fixado dos dois lados; o porta-bebês está corretamente fixado quando escuta um clique e quando a peça na base do porta-bebês (9) mostra a cor verde.

2c. Para retirar o porta-bebês da base, levante a alavanca da base (11) e puxe para cima.

2d. Girar a asa na posição número 4 ou 2, como se mostra na figura 2e.

3. INSTALAÇÃO DA CADEIRA COM CINTO

Para colocar o porta-bebês sem a base deve utilizar-se o cinto do automóvel da seguinte maneira:

3a. Coloque o porta-bebês no assento do veículo, colocando a asa de transporte na posição 5, conforme se mostra na figura 2e. Fixe o cinto de segurança passando-o por cima da asa de transporte.

3b. Introduza a parte abdominal do cinto do automóvel pelas ranhuras na asa (5)..

3c. A parte diagonal do cinto de segurança do veículo deve passar pela parte posterior do porta-bebês, passando a fita pela guia do cinto (2). Tense o cinto do automóvel.

Retire as folgas da fita do cinto de segurança do veículo puxando a parte diagonal deste até que a cadeira fique fortemente fixada.



4. SEGURAR A CRIANÇA NA CADEIRA

Uso de almofada redutora.

Utilize a almofada redutora desde o nascimento até aos 61 cm aproximadamente. É recomendável o uso da almofada redutora para lá dos 61 cm, sempre que seja compatível com o tamanho do bebé.

Colocar a criança na cadeira.

4a. Abra a fivela pressionando o botão vermelho, afastando os conectores para facilitar a instalação do bebé.

4b. Acomode o bebé na cadeira, colocando o arnês de segurança a fixar a fivela.

4c. Para ajustar o apoio para a cabeça, abra a tampa na parte posterior do porta-bebés. Desloque a guia do cinto (2) para cima para deixar cair a tampa.

4d. Apertar a alavanca para regular a altura do apoio para a cabeça.

4e. Deve ficar na posição correta, isto significa que a saída do arnês na zona dos ombros deve ficar aproximadamente 1 cm por cima dos ombros **4f.** Voltar a fechar a tampa.

4g. Assim que a criança estiver corretamente colocada, tense o arnês puxando a fita e assegurando-se que fica bem ajustado.

Entende-se por tensão correta não deixar mais de 1 cm de folga entre a fita do arnês e o bebé à altura do peito (colocar um dedo entre o bebé e o arnês).

Retirar a criança do assento.

4h. Relaxe os cintos do arnês pressionado o botão tensor. Posteriormente, abra a fivela e retire a criança **4a.**

ATENÇÃO! Os cintos não devem ficar retorcidos. O fecho do arnês deve ficar corretamente fechado e os cintos devem ficar bem ajustados à criança.

PT



5. COLOCAR A CADEIRA NO CARRINHO

5a. Com a asa na posição 4 (figura 2e), encaixe o porta-bebés com a fixação do carrinho até escutar um clique.

5b. Para retirar o porta-bebés do carrinho, aperte o botão do profix (10) puxando o porta-bebés para cima.

MANUTENÇÃO

Retirar / Colocar a fronha

A fronha da cadeira ONE é muito simples de retirar. Na parte frontal existem 2 pontos de fixação da fronha. Por favor, solte estes pontos e estique suavemente a parte frontal da fronha.

Nas partes laterais da cadeira existem umas peças plásticas que servem para a fixação da fronha. Basta esticar com suavidade para poder retirar a fronha.

Para voltar a colocar a fronha faça o processo inverso. Para as partes laterais coloque as peças na ranhura.

Limpeza

A fronha pode ser lavada na máquina usando detergente suave e a uma temperatura máxima de 30 graus. Por favor, veja as instruções de lavagem na etiqueta da fronha.

Não utilize secador, já que o acolchoado pode separar-se do têxtil.

Não exponha o estofa ao sol durante longos períodos, enquanto a cadeira não estiver a ser usada cubra-a ou guarde-a no porta-bagagens.

As partes plásticas podem ser limpas com um pano húmido e detergente neutro.

Recomendações

Guarde este livro de instruções para futuras consultas. Leve-o sempre no compartimento debaixo da base.

Assegure-se de que dentro do automóvel, tanto a bagagem como qualquer outro objeto suscetível de causar lesões em caso de acidente estão devidamente fixados ou resguardados.



IT

AVVERTENZE	46
COMPONENTI	48
1. INSTALLAZIONE DELLA BASE	49
2. INSTALLAZIONE DEL SEGGIOLINO SULLA BASE	50
3. INSTALLAZIONE DEL SEGGIOLINO CON CINTURA	50
4. FISSARE IL BAMBINO SUL SEGGIOLINO	51
5. POSIZIONARE IL SEGGIOLINO SUL PASSEGGINO	52
MANUTENZIONE	52





IT

AVVERTENZE

Questo sistema di trattenuta per bambini è stato omologato secondo il Regolamento 129,01 per bambini tra i 40 cm e gli 86 cm di altezza.

Non utilizzare il seggiolino rivolto verso il senso di marcia con bambini di età inferiore a 15 mesi.

Non lasciare il bambino privo di vigilanza dentro il veicolo.

Leggere attentamente le istruzioni.

Un'installazione non corretta del sistema di trattenuta per bambini potrebbe causare danni gravi al bambino. In questo caso il fabbricante non avrà alcun tipo di responsabilità.

Questo seggiolino corrisponde alla categoria Isize definita nel Regolamento 129,01

delle Nazioni Unite e può essere installata in tutti i veicoli Isize omologati secondo il Regolamento 16.

Consultare il manuale di istruzioni del veicolo per sapere se l'installazione dei seggiolini di sicurezza per bambini è possibile.

Non utilizzare il seggiolino di sicurezza senza il rivestimento e senza le protezioni per l'imbragatura.

Proteggere il sistema di trattenuta per bambini dal contatto diretto con la luce solare, dato che le parti in plastica e metallo potrebbero scaldarsi e provocare scottature al bambino.

Mantenere il sistema di trattenuta per bambini lontano da liquidi corrosivi, pitture

46





o solventi che possano danneggiare l'integrità del seggiolino.

In caso di incidente è necessario sostituire il sistema di ritenuta per bambini, anche se non ci sono danni visibili. Il prodotto potrebbe avere danni interni non visibili che mettono a rischio la sicurezza del bambino.

Fare delle fermate durante il viaggio per consentire al bambino di camminare e giocare fuori dal seggiolino. Si consiglia di non superare le due ore di viaggio senza fare fermate. Nel caso dei bambini molto piccoli, questo consiglio è di grande importanza.

Assicurarsi che la barra d'appoggio sia sempre a contatto con il fondo del veicolo e che l'imbragatura del bambino sia correttamente tesa e non sia attorcigliata.

Il rivestimento in tessuto è parte integrante del sistema di ritenuta per bambini. Non può essere sostituito da nessun altro rivestimento senza l'autorizzazione esplicita del fabbricante.

Non modificare il prodotto togliendo o aggiungendo accessori di nessun genere.

Seguire attentamente le istruzioni per il montaggio del prodotto

Non lasciare bagagli non fissati all'interno del veicolo, dato che in caso di incidente potrebbero essere sbalzati e provocare danni gravi agli occupanti del veicolo.

In caso di dubbi contattare:

www.babybecool.es

IT





IT

1. Poggiatesta
2. Guida per la cintura di sicurezza
3. Sistema antiribaltamento
4. Cintura di sicurezza a 3 punti
5. Guida per la cintura di sicurezza
6. Pulsante per tendere l'imbragatura
7. Pulsante per sbloccare la maniglia
8. Sistema Profix
9. Indicatore di installazione corretta del seggiolino
10. Pulsante di sblocco del sistema Profix
11. Leva di sblocco del seggiolino
12. Pulsante di sblocco del sistema Profix
13. Barra di appoggio
14. Maniglia per il trasporto
15. Pulsante di sblocco Isofix
16. Pulsante di regolazione dell'Isofix





1. INSTALLAZIONE DELLA BASE

Per installare il sistema di trattenuta per bambini ONE compiere i seguenti passi:

- 1a.** Installare il sistema antirotazione (3) fino a sentire un "clic".
- 1b.** Distendere la barra (13) fino a portarla in posizione verticale, come indicato.
- 1c.** Spostare il pulsante (15) per portare l'ISOFIX (14) all'indietro stendendo completamente il connettore. Realizzare la stessa operazione per entrambi i connettori.
- 1d.** Guidare i connettori verso gli ancoraggi ISOFIX del veicolo finché non si agganciano emettendo un "clic" e l'indicatore non passa dal colore rosso al verde su entrambi i lati della base.
- 1e.** Spostare indietro il seggiolino premendolo contro lo schienale del sedile del veicolo. Poi tirare il seggiolino per assicurarsi che sia correttamente fissato.

1f. Premere il pulsante (12) per regolare l'altezza della barra di appoggio (13) e assicurarsi che sia a contatto con il fondo del vicolo. Non deve trovarsi sopra nessuno scompartimento. In questo punto assicurarsi che la barra di appoggio e la base del seggiolino formino un angolo di 90°.

Gli indicatori visivi dell'ISOFIX mostrano se il connettore è chiuso o aperto. Può succedere che sia chiuso senza essere fissato all'ancoraggio ISOFIX. Si prega di verificare che i connettori siano fissati correttamente all'ancoraggio del veicolo tirando il seggiolino dopo la sua installazione.

Per disinstallare il seggiolino compiere gli stessi passi all'inverso:

1g. Premere il pulsante (10) per aprire il connettore e liberare gli ancoraggi.

IT





IT

2. INSTALLAZIONE DEL SEGGIOLINO SULLA BASE

Per posizionare il seggiolino sulla base compiere i seguenti passi:

- 2a.** Appoggiare delicatamente il seggiolino sulla base.
- 2b.** Verificare che si sia agganciato su entrambi i lati. Il seggiolino è fissato correttamente quando si sente un "clic" e si vede che l'elemento sulla base del seggiolino (9) diventa di colore verde.
- 2c.** Per ritirare il seggiolino dalla base, sollevare la leva della base (11) e tirare verso l'alto.
- 2d.** Girare la maniglia nella posizione numero 4 o 2, come indicato nella figura 2e.

3. INSTALLAZIONE DEL SEGGIOLINO CON LA CINTURA

Per posizionare il seggiolino senza la base utilizzare la cintura di sicurezza del veicolo nel modo seguente:

- 3a.** Posizionare il seggiolino sul sedile del veicolo, mettendo la maniglia di trasporto nella posizione 5, come indicato nella figura 2e. Fissare la cintura di sicurezza facendola passare sopra la maniglia per il trasporto.
- 3b.** Introdurre la parte addominale della cintura dell'auto nelle fessure della maniglia (5).
- 3c.** La parte diagonale della cintura di sicurezza del veicolo deve passare dietro la parte posteriore dell'ovetto, utilizzando la guida per la cintura (2). Tendere la cintura dell'auto.

Tendere la cintura di sicurezza del veicolo tirando la parte diagonale finché il seggiolino non è fissato fermamente.

50





4. FISSARE IL BAMBINO SUL SEGGIOLINO

Uso del cuscino riduttore.

Utilizzare il cuscino riduttore dalla nascita fino ai 61 cm circa. Si raccomanda l'uso del cuscino riduttore anche superati i 61 cm, purché sia compatibile con le dimensioni del bambino.

Posizionare il bambino sul seggiolino.

4a. Aprire la fibbia premendo il pulsante rosso e spostare i connettori per facilitare il posizionamento del bambino.

4b. Sistemare il bambino sul seggiolino e mettergli l'imbragatura di sicurezza. Chiudere la fibbia.

4c. Per regolare il poggiatesta, aprire la copertura nella parte posteriore del seggiolino. Spostare la guida per la cintura (2) verso l'alto per lasciar cadere la copertura.

4d. Stringere la leva per regolare l'altezza del poggiatesta.

4e. Deve trovarsi nella posizione corretta: questo significa che nella zona delle spalle la cintura deve uscire circa 1 cm sopra le spalle **4f.** Richiudere la copertura.

4g. Quando il bambino è posizionato correttamente, tendere l'imbragatura tirando la cintura. Assicurarsi che sia ben fissato.

La cintura è tesa correttamente quando tra la cintura e il petto del bambino lo spazio è inferiore a 1 centimetro (infilare un dito tra il bambino e la cintura).

Togliere il bambino dal seggiolino.

4h. Allentare le cinture dell'imbragatura premendo l'apposito pulsante. Poi aprire la fibbia e togliere il bambino **4a.**

ATTENZIONE! Le cinture non devono essere attorcigliate. La fibbia dell'imbragatura deve essere chiusa correttamente e le cinture devono esser ben aderenti al bambino.

IT





IT

5. POSIZIONARE IL SEGGIOLINO SUL PASSEGGINO

5a. Con la maniglia in posizione 4 (figura 2e), incastare il seggiolino sull'ancoraggio del passeggino fino a sentire un clic.

5b. Per rimuovere il seggiolino dal passeggino premere il pulsante del PROFIX (10) tirando il seggiolino verso l'alto.

MANUTENZIONE

Rimuovere / Posizionare il rivestimento

Il rivestimento del seggiolino ONE è molto semplice da togliere. Nella parte frontale ci sono 2 punti di fissaggio della fodera. Si prega di liberare questi punti e di tirare delicatamente la parte frontale del rivestimento.

Sui lati del seggiolino ci sono alcuni elementi di plastica che servono per fissare il rivestimento. È sufficiente tirare delicatamente per poter rimuovere il rivestimento.

Per rimettere il rivestimento, effettuare il procedimento inverso. Sui lati, posizionare gli elementi nella fessura.

Pulizia

Il rivestimento può essere lavato in lavatrice usando un detergente delicato a una temperatura massima di 30°. Si prega di seguire le istruzioni per il lavaggio che si trovano sull'etichetta del rivestimento.

Non mettere in asciugatrice, dato che l'imbottitura potrebbe separarsi dal tessuto.

Non esporre il rivestimento al sole per lunghi periodi. Quando il seggiolino non è in uso, coprirlo o riporlo nel bagagliaio.

Le parti in plastica si possono pulire con un panno umido e un detergente neutro.

Raccomandazioni

Conservare il presente libretto di istruzioni per consultazioni future. Riporlo sempre nello scompartimento sotto la base.

Assicurarsi che dentro l'auto, sia i bagagli che qualunque altro oggetto suscettibile di provocare danni in caso di incidente siano correttamente fissati e protetti.

52





IT



53



The logo for 'be cool' features a stylized lowercase 'b' in red with a white dot, followed by the words 'be cool' in a dark blue, lowercase, sans-serif font.





JANÉ GROUP

Pol. Ind. Riera de Caldes - C/. Mercaders, 34
08184 PALAU DE PLEGAMANS - Barcelona (SPAIN)

JANE, S.A. NIF: ES A08234999

info@groupjane.com

www.babybecool.es



IM 2041,01

