

CONCORD **NEO**

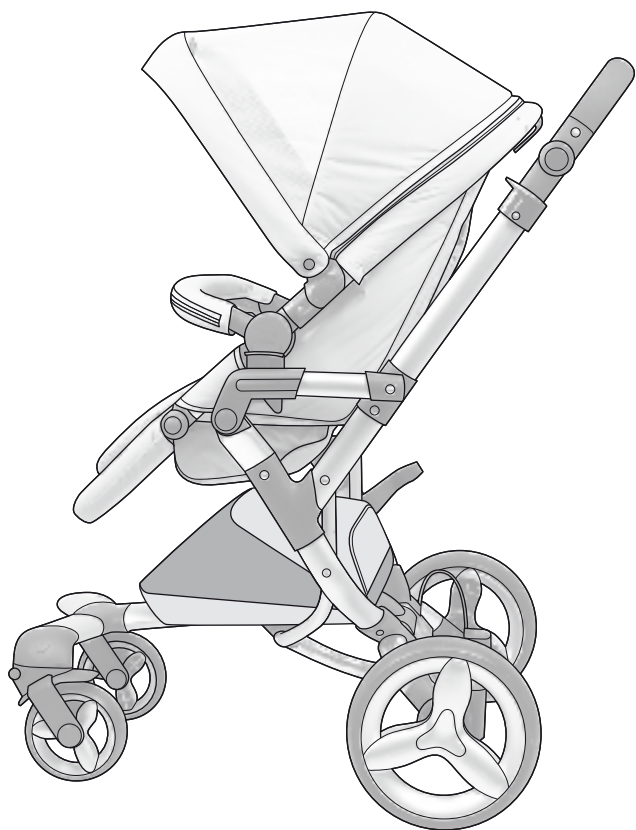

_ ENGLISH

OVERVIEW	26
THANK YOU!	28
PLEASE NOTE	28
ATTACHING AND REMOVING THE BACK WHEELS	30
UNFOLDING AND FOLDING	32
ATTACHING AND REMOVING THE SEAT FRAME (PROFIX SYSTEM)	33
SETTING THE SEAT ANGLE	35
USING THE SAFETY BAR	36
USING THE SUN SHADE	37
ADJUSTING THE HANDLEBAR	38
ADJUSTING THE FOOTREST	39
USING THE HARNESSING SYSTEM	40
USING THE PARKING BRAKE	42
LOCKING THE FRONT WHEELS	42
USING THE WIND PROTECTOR	43
USING THE RAIN COVER	44
PUTTING ON, REMOVING AND LAUNDERING THE COVER	45
CONCORD ORIGINAL SPARE PARTS/ACCESSORIES	45
GUARANTEE	46

_ OVERVIEW

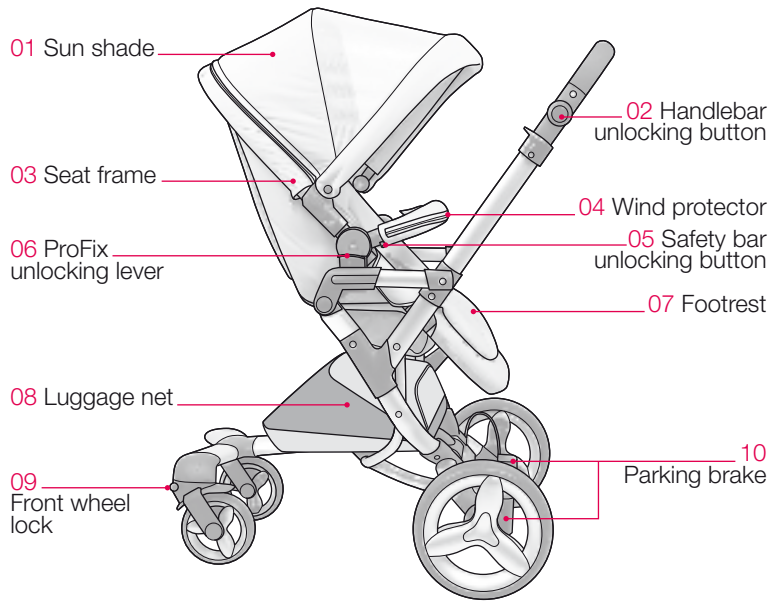

_ THANK YOU!

You have made a good choice with this Concord quality product. You will be impressed by the versatility and safety of this product. We hope you will have lots of fun with your new CONCORD NEO.

_ PLEASE NOTE

IMPORTANT!

- Please read the instructions carefully before using the CONCORD NEO for the first time and retain them for future reference. Failure to comply with the guidelines set out below can put the child's safety at risk!

WARNING!

- The CONCORD NEO is suitable for children up to about 3 years of age and weighing not more than 15 kg.
 - The CONCORD NEO is only suitable for children under 6 months in conjunction with approved Concord accessories.
 - Only allow one child to sit or lie in the CONCORD NEO at a time.
 - The CONCORD NEO is not a child car seat! Only transport your children in tested, approved child seats.
 - Some Concord accessory products are fitted with adaptors suitable for the CONCORD NEO, making it easy to attach them to the CONCORD NEO. Make sure that the Concord accessory has engaged properly with the CONCORD NEO prior to use.
 - Never leave your child unsupervised.
 - Never let children play with the CONCORD NEO.
 - Always use the safety belts when the child is sitting or lying in the CONCORD NEO.
 - Any load that is attached to the handle of the CONCORD NEO (such as bags), limits the stability of the CONCORD NEO.
- You should take the child out of the CONCORD NEO whenever you have to manoeuvre stairs or steep slopes.
 - The CONCORD NEO is not suitable for jogging or skating.
 - Never allow a child to stand on the connecting rods between the wheels of the CONCORD NEO. This can damage the CONCORD NEO and impair its safety.
 - Before using the CONCORD NEO, make sure that all fastening and locking devices are properly engaged and securely locked.
 - Check all the parts of the CONCORD NEO, and the accessories used, at regular intervals.
 - Make sure the child is not in the baby buggy before putting on or removing the cover or the approved Concord accessory.
 - Only use Concord original spare parts / accessories.
 - The guarantee does not apply if the CONCORD NEO is damaged through excess strain, incorrect usage or the use of other spare parts / accessories.
 - Sunlight may cause a slight discoloration of parts of the CONCORD NEO.
 - Please avoid exposing the CONCORD NEO to extreme temperatures.
 - Throw away all plastic packaging immediately. It can put your child's life at risk.

_ ATTACHING AND REMOVING THE BACK WHEELS

You must attach the rear wheels before using the CONCORD NEO for the first time. First, remove the wheel cover. To do so, guide the axle through the hub from the inside of the wheel and push the cover off. Now press the two rings at the end of the axle together and pull the axle out of the hub.

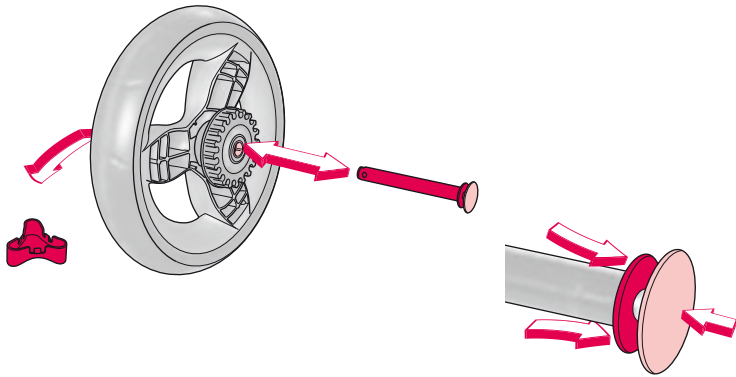

Guide the axle through the hub from the front of the wheel. Press on the cover until it snaps into position.

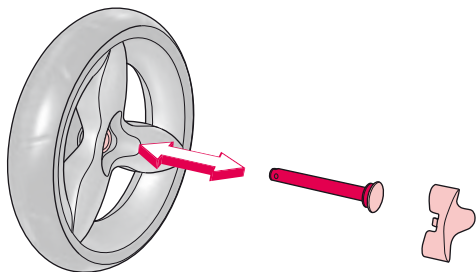

To attach the back wheel, press and hold the pushbutton as you push the wheel onto the CONCORD NEO axle, and let it click audibly into place.

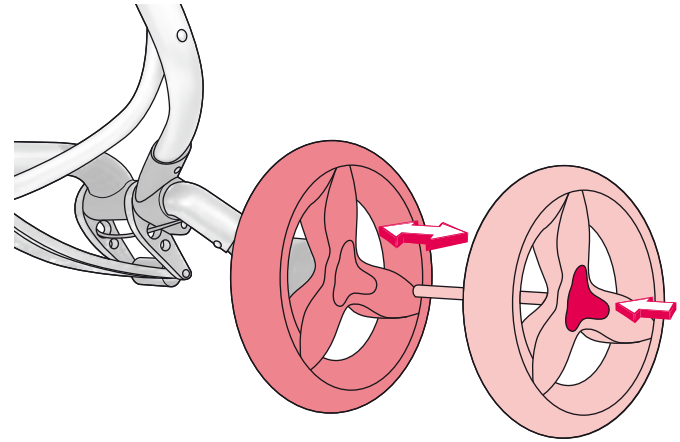

To remove a back wheel, press and hold the pushbutton (19) and pull the wheel off the axle.

_ UNFOLDING AND FOLDING

To set up the CONCORD NEO, first release the transport lock (18) by pressing it downwards or backwards. Then pull the handlebar (11) upwards until it engage with a clear click.

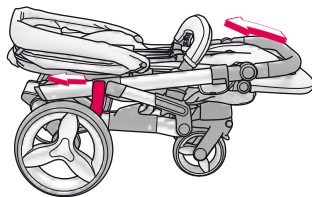

To fold down the CONCORD NEO, first adjust the seat angle on the seat frame (03) to position P (see ADJUSTING THE SEAT ANGLE).

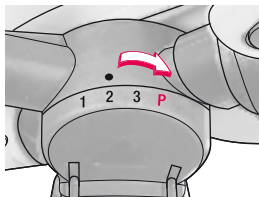

The unlocking levers are located on the left and right of the handle. To unlock, press and hold the safety button on the inside of the right unlocking lever (13) and pull both unlocking levers upwards. Now push the handlebar forwards/down until the transport locking device engages.

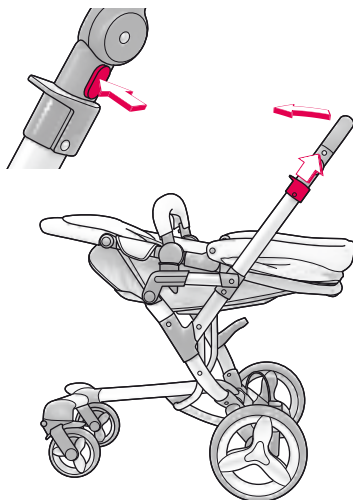

_ ATTACHING AND REMOVING THE SEAT FRAME (PROFIX SYSTEM)

The CONCORD NEO is equipped with ProFix adapters (15). These adapters are used to attach the CONCORD NEO seat frame to the chassis. You can secure the seat frame to the chassis so that it is either front or rear facing. To do this, insert the seat frame from above into the receivers on the chassis and let it click audibly into place.

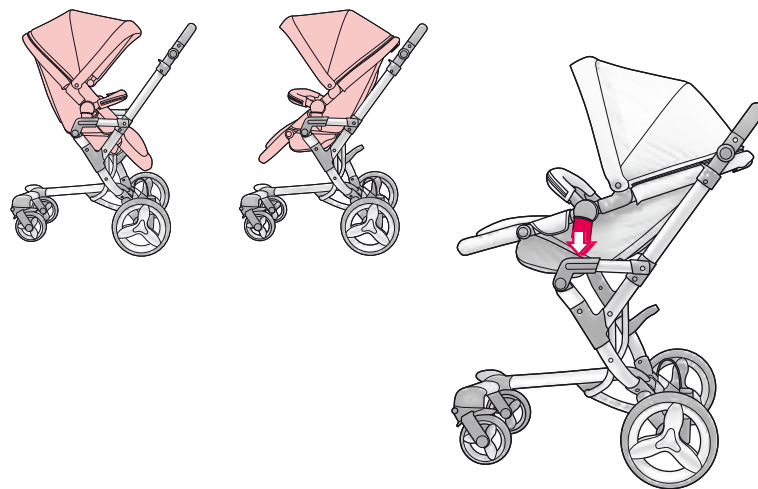

WARNING

- Never seat your child in the seat frame until after you have secured the frame to the chassis.
- Before using the CONCORD NEO, ensure that all fixing mechanisms and fastenings are properly locked in position and closed.
- Never remove the seat frame from the chassis while a child is sitting in it.

To remove the seat frame from the chassis, pull simultaneously on the right and left ProFix unlocking levers (06) on the seat frame and pull the frame upwards and away from the chassis.

Tip: Various elements can be attached to the CONCORD NEO by means of the ProFix adapter. Some Concord accessories, available from specialist retailers, are equipped with adapters suitable for the CONCORD NEO, making it easy to attach them to the CONCORD NEO. Check before use that the Concord accessory has engaged properly in the CONCORD NEO. Please also refer to the instructions for use enclosed with the relevant Concord accessory.

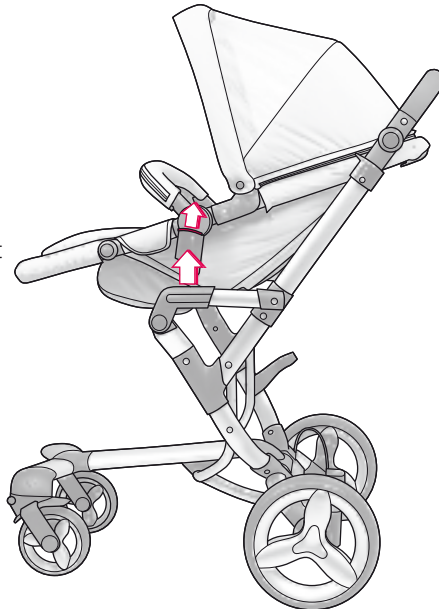

_ SETTING THE SEAT ANGLE

You can set the seat frame's angle of inclination to several positions. To do this, pull the adjustment handle (12) on the top edge of the seat frame and adjust the seat angle until it engages in the required position.

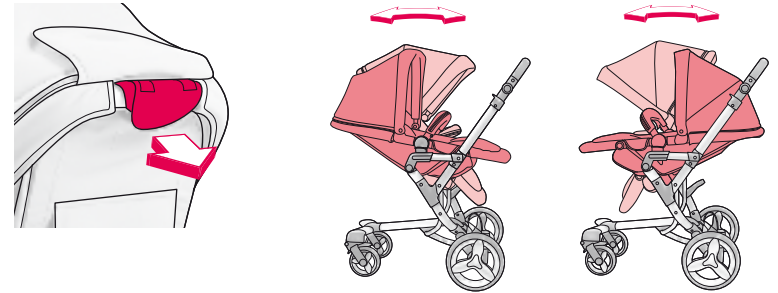

WARNING

- An additional position (P) allows the CONCORD NEO to be folded down extra compactly, but it must be used solely for this purpose and never for transporting a child.

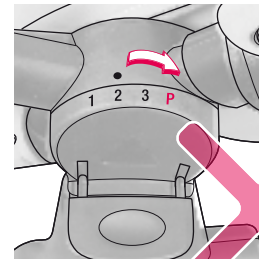

_ USING THE SAFETY BAR

The safety bar (14) on the CONCORD NEO engages in the receivers provided for this purpose in the seat frame. You can open the safety bar on both sides or just on one. To do this, press the relevant unlocking buttons (05) on the left and right of the seat frame.

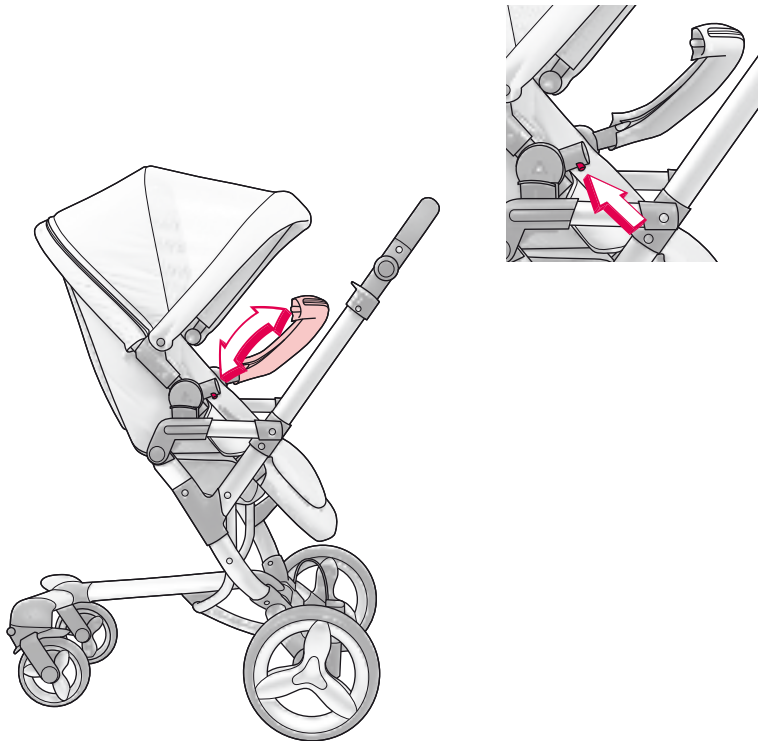

_ USING THE SUN SHADE

To secure the CONCORD NEO sun shade (01) onto the seat frame, push it from above onto the relevant plastic receivers on the seat frame. Then join the zip on the inside of the sun shade to the seat cover.

To remove the sun shade, undo the zip and pull the sun shade upwards and away from the seat frame.

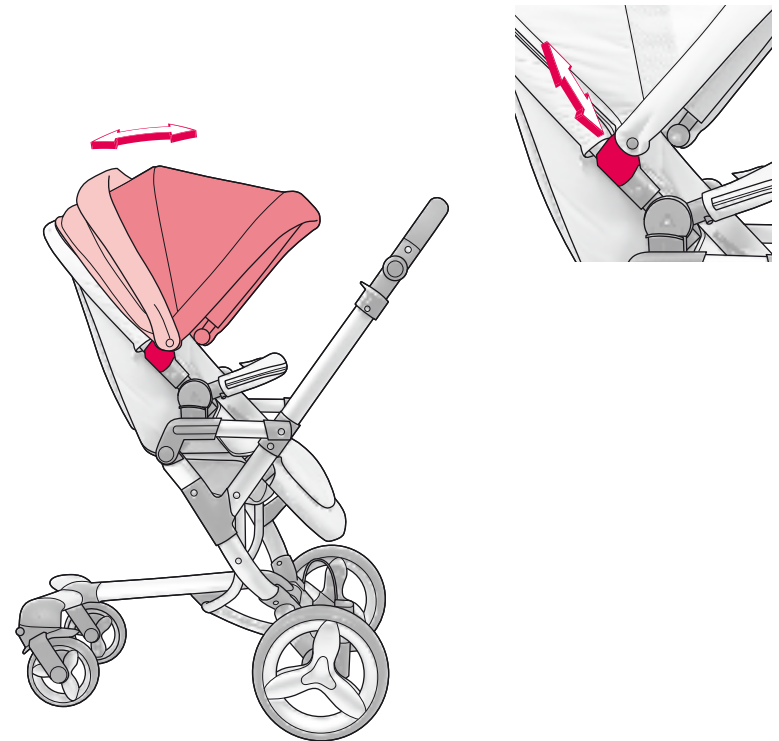

_ ADJUSTING THE HANDLEBAR

The handlebar can be adjusted to seven different positions. To do this, release the positioning mechanism by pressing both the unlocking buttons (02) on the left and right of the handlebar and move the bar until it engages in the next position.

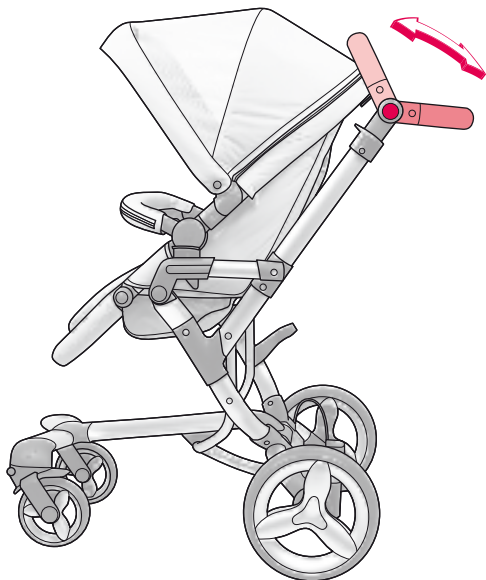
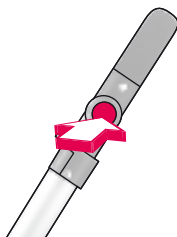

_ ADJUSTING THE FOOTREST

You can adjust the footrest (07) to five different positions. To do this, simultaneously press the left and right unlocking buttons (16). Then adjust the footrest until it engages in the required position.

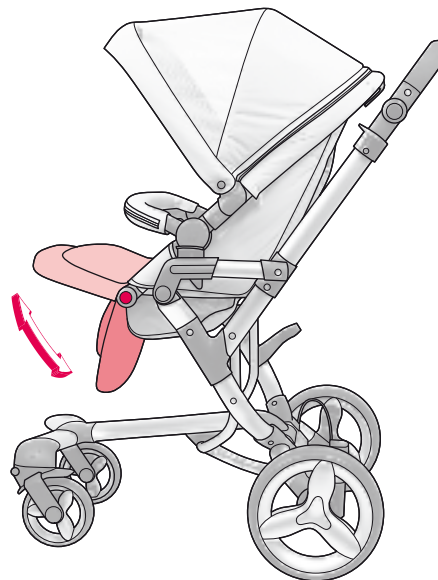
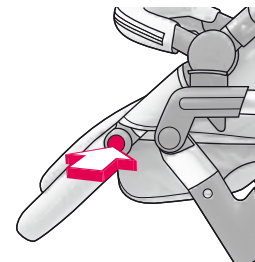

_ USING THE HARNESSING SYSTEM

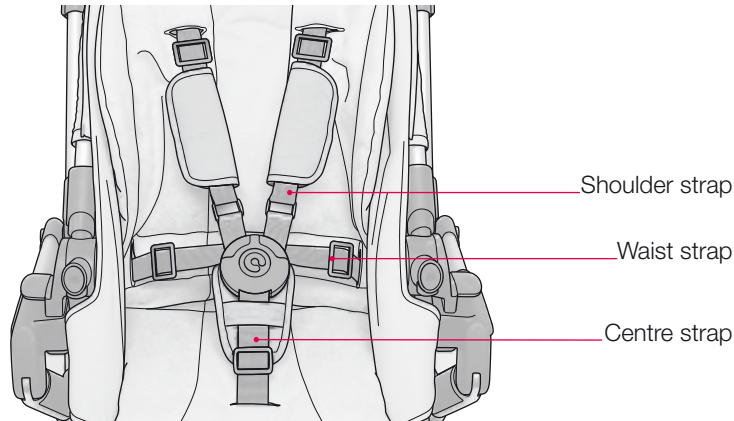

Feed the centre strap with the buckle between the child's legs. Then insert the buckle adaptors on the shoulder and waist straps from above into the top of the buckle. They should click audibly into position.

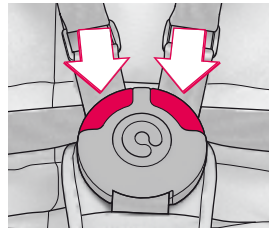

To open the harness system, press the button in the middle of the buckle until the buckle adaptors are released..

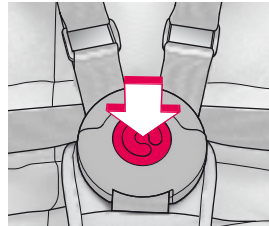

Take care that your child is always strapped in, with the buckle fastened, whenever you go out with the pushchair.

Adjust the straps so that they are taut and lie close against the child. To adjust the strap length, slide the strap clasps up or down. Check that the straps are not twisted.

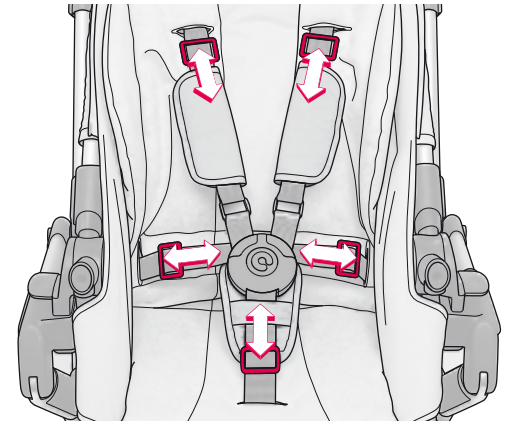

The childproof lock is on the back of the buckle. This can be activated and deactivated by turning. Activating the childproof lock locks the buckle opening mechanism.

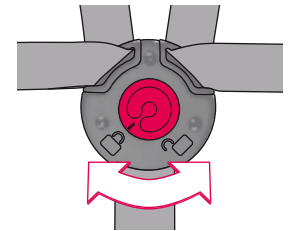

WARNING!

- Always use the shoulder and waist straps together with the centre strap.

_ USING THE PARKING BRAKE

To activate the CONCORD NEO's parking brake (10), push up the foot pedal on the left back wheel.

To release the parking brake, push down the pedal on the left back wheel.

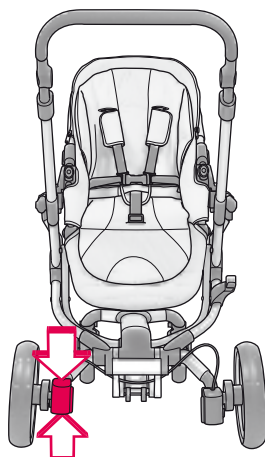

_ LOCKING THE FRONT WHEELS

To locate the front wheels of the CONCORD NEO, align the front wheels towards the back and slide the locking button (09) from the outside inwards.

To release the wheels, slide the locking button from the inside to the outside.

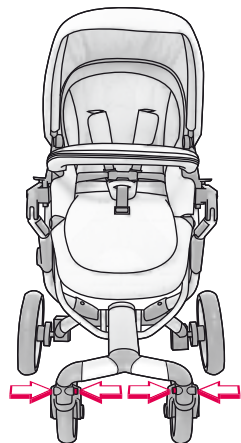

_ USING THE WIND PROTECTOR

The CONCORD NEO is equipped with an integrated wind protector (04). To use it, undo the zip on the safety bar and stretch the wind protector across the footrest.

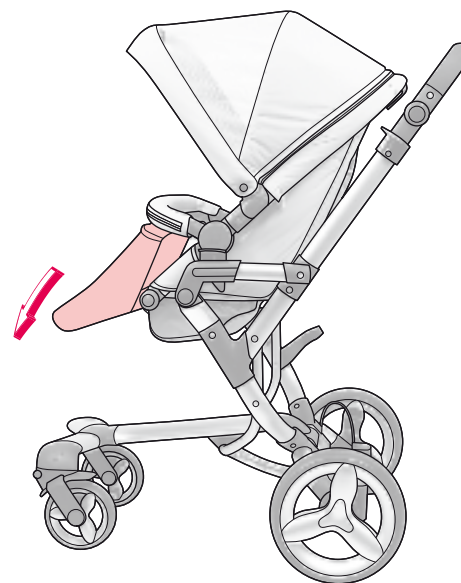

_ USING THE RAIN COVER

The rain cover for the CONCORD NEO is located in the pocket (17) underneath the seat frame. It is secured to the sun shade by means of the zip.

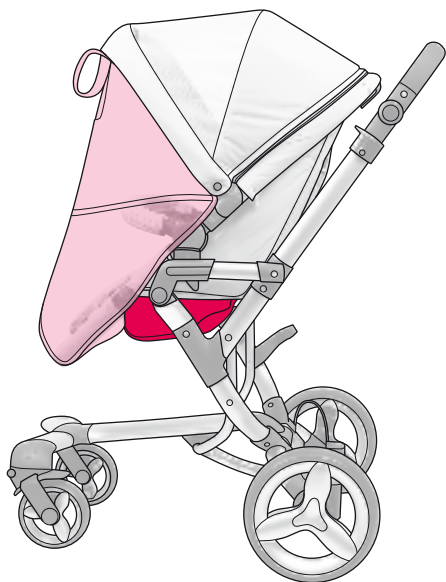

_ PUTTING ON, REMOVING AND LAUNDERING THE COVER

The different parts of the cover of the CONCORD NEO are joined to each other by means of press-studs, Velcro and zip fasteners, and are attached to the rods. If you wish to remove the cover, first loosen all these fastenings.

Make sure all the fasteners and connections are done up safety when you put the cover on.

You can wipe all parts of the cover as well as the rods and the plastic parts of the CONCORD NEO with a damp cloth.

_ CONCORD ORIGINAL SPARE PARTS/ACCESSORIES

Information on Concord original spare parts/accessories is available at your retailer's or directly from Concord.

Concord GmbH
Industriestraße 25
95346 Stadtsteinach
Germany

Phone +49 (0)9225.9550-0
Fax +49 (0)9225.9550-55
info@concord.de

www.concord.de

_ GUARANTEE

The guarantee begins on the day of purchase. The guarantee period corresponds to the statutory warranty period in the end-user's country concerned. At the manufacturer's discretion, the guarantee shall cover rectification, replacement or a price reduction.

The guarantee is valid for the original purchaser only. In the event of any defect, claims can not be considered unless the specialist dealer is notified of the fault as soon as it occurs for the first time. If the specialist dealer is unable to remedy the problem himself, he must return the product to the manufacturers together with details of the complaint, official proof of purchase and the purchase date. The manufacturers assume no liability for faulty goods that they did not supply.

The guarantee does not apply where:

- the product has been modified;
- the product is not brought back to the specialist dealer complete with proof of purchase within 14 days of the defect occurring;
- the defect was caused by improper usage or maintenance or due to anything else deemed to be the fault of the user, in particular failure to comply with the instructions for use;
- repairs have been carried out on the product by third parties;
- the defect was caused as the result of an accident.

The guarantee makes no provision for any alteration or deterioration to the product that is incurred through normal usage (wear and tear). The period of guarantee shall not be extended by any remedial measures carried out by the manufacturers in the event of a claim.

_ DEUTSCH	Einbau- und Bedienungsanleitung
_ ENGLISH	Instructions for attachment and use
_ FRANÇAIS	Directives d'installation et mode d'emploi
_ ESPAÑOL	Instrucciones de montaje y de uso
_ ITALIANO	Istruzioni per l'uso e il montaggio
_ PORTUGUÊS	Manual de montagem e de utilização
_ NEDERLANDS	Inbouw- en bedieningshandleiding
_ MAGYAR	Beszerezési és kezelési útmutató
_ ČESKY	Návod k montáži a obsluze
_ NORSK	Bruksanvisning og monteringsveiledning
_ DANSK	Monterings- og betjeningsvejledning
_ SLOVENSKO	Navodila za vgradnjo in uporabo
_ POLSKI	Instrukcja montażu i obsługi
_ TÜRKÇE	Montaj ve Kullanma Kılavuzu
_ SLOVENSKY	Návod na montáž a obsluhu
_ HRVATSKI	Naputak za montažu i uporabu

Concord GmbH
Industriestraße 25
95346 Stadtsteinach
Germany

Phone +49 (0)9225.9550-0
Fax +49 (0)9225.9550-55
info@concord.de

www.concord.de

NE 04/1207

